

DETERMINATION OF ROLLING RADIUS OF SELF-PROPELLED MACHINES' WHEELS

ВИЗНАЧЕННЯ ДІЙСНОГО РАДІУСУ КОЧЕННЯ ТА ОЦІНКА КОВЗАННЯ КОЛІС САМОХІДНИХ МАШИН

Prof.PhD.Eng. Golub G.A., Ph.D. Eng. Chuba V.V., Ph.D. Eng. Marus O.A.
National University of Life and Environmental Sciences of Ukraine, Kyiv / Ukraine;
Tel:+380953115050, E-mail gagolub@ukr.net

Keywords: wheel deformation, tire air pressure, wheel contact area, wheel slipping, pneumatic tires

ABSTRACT

The obtained results allow calculating the actual rolling radius of the wheel and evaluate the slipping of the drive wheels of self-propelled machines in accordance with the air pressure in the tires and the parameters of interaction with the support surface.

On the basis of the developed model for determining the initial radius of the wheel and the length of the contact zone of the wheel with the support surface, the dependence for determining the actual radius of the wheel rolling was obtained.

The studies have confirmed an increase in the actual rolling radius and a decrease in wheel slip with an increase in air pressure in the tires. For example, for the rear wheel of a tractor John Deere 7130 with an increase in pressure from 0.6 to 2.6 atm, an increase in the rolling radius by 21 mm and a decrease in the slip coefficient from 1.94 to 0.83% were observed. For the front wheel, when the pressure changed from 1 to 2 atm, the rolling radius increased by 7 mm and the wheel slip coefficient decreased from 1.76 to 1.12 %. The determination index of calculated and experimental values of the real rolling radius is $\eta^2 = 0.98$ for the front and $\eta^2 = 0.99$ for the rear wheels, which indicates the adequacy of the calculated dependences.

РЕЗЮМЕ

Отримані результати дають змогу виконати розрахунок дійсного радіуса кочення колеса та оцінити ковзання приводних коліс самохідних машин відповідно до тиску повітря в шинах та параметрів взаємодії з опорною поверхнею.

На основі розробленої моделі для визначення початкового радіуса колеса та довжини зони контакту колеса з опорною поверхнею отримано залежність для визначення дійсного радіуса кочення колеса.

Виконані дослідження підтвердили збільшення дійсного радіуса кочення та зменшення ковзання колеса при збільшенні тиску повітря в шинах. Так, наприклад, для заднього колеса трактора John Deere 7130 при збільшенні тиску від 0,6 до 2,6 атм спостерігалось збільшення радіуса кочення на 21 мм та зменшення коефіцієнта ковзання від 1,94 до 0,83%. Для переднього колеса при зміні тиску від 1 до 2 атм спостерігалось збільшення радіуса кочення на 7 мм та зменшення коефіцієнта ковзання коліс від 1,76 до 1,12 %. Індекс детермінації розрахункових та експериментальних значень дійсного радіуса кочення становить $\eta^2 = 0,98$ для передніх та $\eta^2 = 0,99$ для задніх коліс, що свідчить про адекватність отриманих розрахункових залежностей.

INTRODUCTION

In most studies concerning the movement of wheel propellers, carried out in the middle of the last century, it was considered a static radius of rolling wheels (Bekker, 1956; Dwyer et al., 1974). However, this approach is valid only for wheels that are not subjected to deformation.

Modern studies of the mechanics of interaction between the drive wheel and the support surface are aimed at improving the technical means and control systems of optimal modes of self-propelled machines movement (Gray et al., 2016; Taghavifar and Mardani, 2015). Such systems require precise measurements and the minimum errors in the calculations. The rolling radius of the wheel is an important parameter because it determines the interaction of the wheel with the support surface when converting engine power

into traction. At present, there is no single approach to determining the actual rolling radius of pneumatic wheels during the movement of self-propelled machines.

In the study (Upadhyaya *et al.*, 1998), while testing of agricultural power units traction properties in terms of tires interaction with the soil, it was noted that it was necessary to determine the actual rolling radius of the wheel. The authors consider the possibility of determining the actual rolling radius of the wheel on the basis of testing the rolling self-propelled machine on different soil background. It was found that there was a difference in the values of the wheel rolling radius depending on the presence of traction load and its absence.

It was also investigated the process of rolling the drive wheel with a pneumatic tire on the ground that is deformed (Kiss P, 2003). Based on the conducted researches, three wheel rolling radii are allocated, namely: kinematic radius which arises as a result of existence of slipping (sliding) of a wheel; kinetic radius which is calculated with a ratio of a torque and the reduced movement resistance force of a wheel and geometrical radius – as a distance between the wheel centre and the bottom part of a tire. The author notes the discrepancy and interdependence of this radius.

In the study (Hamersma *et al.*, 2016) theoretical approaches were considered and experimental studies were carried out to determine the kinematic and kinetic radii using modern measuring instruments. The discrepancy between the experimentally obtained radius and the static radius of the wheel was found. The authors presumed the possibility of using the static radius of the wheel to perform simulation of changes in the interaction of the wheel with the support surface.

Those highlighted in the methodological approaches of the works done by Kiss P (2003); Hamersma *et al.* (2016), for determining the rolling radius of the wheel, allow solving the problems of interaction between the wheel and the ground with the corresponding errors, but for the widespread use these approaches require further improvement. Taking into account the nature of the relationship between the wheelset, wheel rotation and the formation of the traction force (Golub *et al.*, 2017), it was proposed to carry out calculations using one real wheel rolling radius.

To date, a certain number of studies based on empirical dependences obtained under different conditions of interaction between the drive wheel and the support surface have been carried out.

According to Jazar (2017), the actual rolling radius of the wheel is proposed to be calculated as follows:

$$R_D = \frac{2}{3} R_u + \frac{1}{2} R_l \quad (1)$$

where R_D – the actual rolling radius of the wheel, m; R_u – the radius of the wheel without load, m; R_l – the radius of the loaded wheel, m.

In the work (Pauwelussen *et al.*, 2007), the actual rolling radius of the wheel is proposed to be determined by semi-empirical dependence:

$$R_D = R_U - \rho_0 \left[D \arctan \left(B \frac{\rho}{\rho_0} \right) + E \frac{\rho}{\rho_0} \right] \quad (2)$$

where ρ – the actual deflection of the tire, m; ρ_0 – the deflection of the tire at rated load, B , D , E – the design parameters of the tire, characterizing the parameters of the tire associated with the nature of deformation of the tire under load, relative units.

In the paper (Wilson *et al.*, 2011), to determine the actual rolling radius depending on the function of drive torque, load, and pressure, it was proposed the dependence based on empirical coefficients:

$$R_D = R_U - \lambda^* \left[1 - (1 - W/W^*) p / p^* \right] T \quad (3)$$

where W – vertical load on the wheel, N; p_w – wheel pressure, kPa; T – torque applied to the wheel, N m; λ^* , W^* , p^* – the empirical factors of the tire longitudinal elasticity, load, and pressure, respectively.

The use of these dependencies, as well as similar ones, make it possible to perform an approximate calculation of the change in the actual rolling radius of the wheel, but in practical use can lead to significant errors.

In their work, Ryan and Bevely (2012), on the basis of application of modern GPS technologies, authors considered possibility of application of operational control of pressure in the tire on the basis of change of the actual rolling radius. The actual rolling radius is proposed to be determined on the basis of the ratio of the vehicle linear velocity and the wheel angular velocity. This approach makes it possible to record the change in radius only in the absence of a change in torque and the absence of wheel slip. In real conditions, there is

always a slip, variable deformation due to the reduced torque and wheel slip. Testing of the similar methodology for determining the actual rolling radius is provided in the paper (Sabatini et al., 2017). In this case, the linear velocity was determined using the GPS sensor, and the angular velocity – with the help of the wheel rotation sensor. The analysis showed a high coincidence between the measured speed of movement with the help of GPS system and calculated based on measurements of the wheel angular speed at uniform motion. The results obtained allow us to assert the possibility of using the proposed method to estimate the change in the real radius of the wheel rolling at constant motion.

The study (Taghavifar and Mardani, 2014) provides theoretical and experimental aspects of occurrence of the drive wheels slipping when loading the vehicle. The authors conclude that there is a paradigm of wheel slipping control depending on its load and operating conditions. To control driving wheels slipping, it is substantiated the necessity of creating an algorithm for parallel control for an instant tire rolling radius and the angular velocity of the wheel.

Considering the relevance of determining the actual radius of the wheel, a number of methods for its experimental determination by measuring the wheel angular velocity of rotation were developed. Thus, in (M'Sirdi et al, 2008) ABS sensors were used to experimentally determine the wheel speed. At a given speed and when measured using a laser ruler of the wheel radius, it was determined the actual stiffness of the tire.

It was also provided the simulation of the wheel radius change at the vehicle speed in the range from 21 to 22 m/s (Tannoury et al, 2011) taking into account the angular velocity, which ranged from 70 to 81.48 rad/s. On the basis of this, the change in the actual wheel radius, which ranged from 30 to 27 cm depending on the ratio of the linear and angular wheel speed, was determined.

The application of a sensitive electronic system for determining the change in the position of the centre of mass is proposed (Huang and Wang, 2013). This made it possible to fix the deformation of the wheel depending on the applied dynamic load. This approach makes it possible to determine the stiffness of the wheel on the basis of changes in the actual radius of the wheel.

The analysis of the studies (M'Sirdi et al, 2008; Tannoury et al, 2011; Huang and Wang, 2013) shows the potential application of different methods to determine the wheel slip, which allows to indirectly draw conclusions about the change in the actual rolling radius of the wheel. The practical value of the application of the analyzed methods can be obtained only in the case of determining the value of the real instantaneous rolling radius, but it is necessary to set the initial value of the real rolling radius.

Investigating the change in the kinematic and power characteristics of a pneumatic wheel in slipping motion (Rubinstein et al., 2018), it is proposed to determine the instantaneous and average rolling radius on the basis of the covered distance and the number of the wheel turns. It is proposed to measure the covered distance using a separate additional measuring wheel. However, a significant drawback of the use of an additional measuring wheel is the need to take into account the slip during its movement, which will depend on the rolling speed and contact interaction with the support surface.

The method of determining the wheel slipping based on the ratio of the linear and angular velocities of the wheel is given in (ASABE Standards, 2013) but it does not provide the parameters of the initial rolling radius of the wheel. While studying the rolling radius of the wheel of an agricultural tire with different density of the soil, it was made the assumption of the existence of the wheel initial rolling radius, which corresponds to a certain initial value of the wheel slipping (Rubinstein et al., 2018). The actual rolling radius of the wheel is determined from the wheel initial rolling radius and the inverse ratio of the initial and final slipping values. On the basis of theoretical and experimental studies it is concluded that the best criterion for determining the wheel initial rolling radius is the condition of the absence of traction force on the wheel.

The analysis of existing publications showed the absence of a unified approach and methodology in determining the actual radius of the wheel rolling during the interaction of the wheel with the support surface. It should also be noted the diverse influence of many parameters of the interaction of the wheel and the bearing surface on the actual radius of the wheel rolling. The inability to determine the actual rolling radius leads to significant errors in the interpretation of experimental and theoretical studies of wheel operation. Setting the actual rolling radius of the wheel will determine the pulling force and slipping of the wheel. Clarification of the method for determining the initial rolling radius of the pneumatic wheel, depending on its design parameters, is an urgent scientific task. The use of modern technological devices for measuring linear and angular velocity at a known initial rolling radius of the wheel will allow determining the instantaneous rolling radius with high accuracy.

The aim of the research is to substantiate the method of determining the actual rolling radius of pneumatic drive wheels of self-propelled machines and its experimental determination.

To achieve the goal, the following tasks were solved:

- to substantiate the conditions and methods for determining the initial radius of the wheel;
- to develop a method for calculating the actual rolling radius of the wheel when deformed by a vertically applied load;
- to perform an experimental determination of the change in the actual rolling radius of the drive wheels of self-propelled machines from changes in the air pressure inside the tire.

MATERIALS AND METHODS

When substantiating the method and determining the initial and actual rolling radius of the drive wheels, the geometric modeling of pneumatic wheel deformation was used. During the movement of wheeled tractors, cars and other self-propelled machines, the deformation of the wheel tires occurs due to the action of the reduced vertical load and the action of the wheel torque. The research was made under the condition of the wheel without applying drive torque. Due to the deformation of the wheel tires, the actual distance covered by the wheel is less than the one the wheel would have covered in the absence of tire deformation. Thus, wheel deformation contributes to the overall wheel slipping.

Most researchers consider the slipping phenomenon as the ratio of the difference between the linear and the real speed of the wheel to the linear one, or the ratio of the difference between the possible and the covered distance to the possible one:

$$\delta = \frac{\omega R_K - V_D}{\omega R_K} = \frac{2\pi R_K n - S_D}{2\pi R_K n} \quad (4)$$

where:

- δ – the coefficient slipping, relative units;
- V_D – the actual speed, m/s;
- ω – the angular velocity of the drive wheel, rad/sec;
- R_K – the driving wheel rolling radius, m;
- n – the number of turns made by the wheel per unit of time, turns per second;
- S_D – the actual distance covered by the wheel for a certain number of the wheel turns, m.

Pneumatic tire of the power unit wheel in contact with the support surface is subjected to the initial deformation from the action of vertical loads of the tractor weight. Since the vertical load on the pneumatic tire can be considered conditionally constant, this state of the deformed wheel can be considered as the initial and must be taken into account when determining the actual initial radius of the wheel rolling. According to the analysis of the literature, the distance from the wheel centre of rotation to the bearing surface of the loaded wheel is not the actual radius of rotation of the wheel and is not suitable for calculations. The actual radius of rotation of the deformed wheel was determined based on the assumption of the existence of the deformed wheel slipping relative to the free undeformed state.

Mathematically, slipping was determined as the difference between the arc length, which is limited by the central angle based on the deflection chord of the wheel tire, and the longest chord of the deflection of the wheel tire, as follows (Fig. 1):

$$\delta_G = \frac{2\pi}{\alpha} \left(\frac{\left(\alpha R - 2R \sin \frac{\alpha}{2} \right)}{\alpha R} \right) = \left(1 - \frac{2}{\alpha} \sin \frac{\alpha}{2} \right) = \left(1 - \frac{L}{\alpha R} \right) = \left(1 - \frac{R_D}{R} \right) \quad (5)$$

where:

- δ_G – the wheel slipping, relative units;
- R – the initial radius of the wheel rolling, m;
- α – the central angle limiting the chord of the wheel tire deflection, rad.
- L – the length of the chord formed by the deflection of the wheel tire, m, we obtain:
- R_D – the actual radius of the deformed wheel rolling, m.

The actual radius of the deformed wheel was determined as follows:

$$R_D = \frac{L}{\alpha} = \frac{L}{2 \arcsin \frac{L}{2R}} \quad (6)$$

The length of the chord in contact with the wheel bearing surface can be easily determined with the help of experimental measurements. It is more difficult to determine the initial radius of the wheel, as the shape and deformation of the wheel are set by design features of the wheel and tread.

Since the initial actual rolling radius is specified by the applied vertical load, the initial radius was considered as the state of the wheel when the tread deformation is caused by the wheel's own weight.

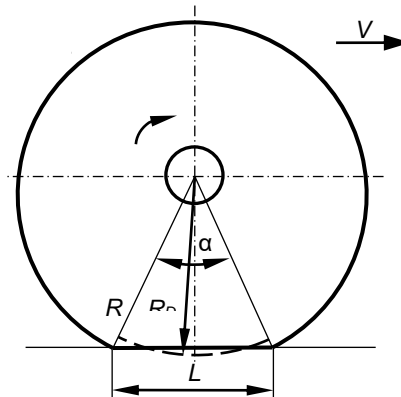

Fig. 1 - A simplified geometric interpretation of the deformation process of the wheel tire

When observing the wheel in the free state, it can be noticed that the cross-section radius is variable. The radius of the wheel in the free state decreases from the centre of the tread to the outer edge. When the wheel is loaded with its own weight, the tread is deformed in the spot of contact with the support surface. The nature of the tread deformation determines the rigidity of the pneumatic tire frame and the internal pressure in the tire.

In this case the change in the radius of the wheel caused by the load of its own weight was determined as follows:

$$\Delta r = \frac{(l_C - l_K)k_{DP}}{2\pi} \quad (7)$$

where:

Δr – reducing the wheel radius relative to the centre of the tread and its edge in cross section, m; l_C – the wheel length in the middle of the tread, m; l_K – the length of the wheel along the edge of the tread, m; k_{DP} – the coefficient of stiffness of the tire, which determines the deformation of the tire in the longitudinal and transverse directions, relative units.

Considering the equation (7), the initial radius of the wheel was defined as follows:

$$R = R_C - \Delta r = \frac{l_C}{2\pi} - \frac{(l_C - l_K)k_{DP}}{2\pi} = \frac{l_C(1 - k_{DP}) + l_K k_{DP}}{2\pi} \quad (8)$$

where:

R_C – the radius of the middle of the wheel tread in the free state, m.

The actual radius of the deformed wheel was defined as follows:

$$R_D = \frac{L}{2 \arcsin \frac{L\pi}{l_C(1 - k_{DP}) + l_K k_{DP}}} \quad (9)$$

An experimental study of changes in the geometric parameters of the contact spot of John Deere series 7130 tractor tires due to changes in tire pressure was performed. In experimental studies, the tractor was equipped with front Goodyear Super Traction Radial 14.9 R24 and rear Firestone Radial 800 460/85 R38 tires.

The length of the tire circle in the centre and the edge of the tread was determined at a given tire pressure for the raised wheel (in the absence of load).

The chord of the wheel contact zone with the support surface under the load of the tractor weight was measured at different tire pressures.

To validate the reliability of the obtained theoretical dependences, an experimental verification of the change in the actual rolling radius of the tractor wheels was performed at the tire pressure changes and at moving along a horizontal concreted site. When determining the actual rolling radius, the necessary tire

pressure was set and the rolling was carried out at a distance of 10 complete turns of the wheel. During the rolling, it was recorded the distance traversed by the wheel during one turn and total covered distance.

After performing 10 turns, averaging of the distance covered by the wheel in one turn was performed. On the basis of the average distance covered in one turn of the wheel, it was determined the actual rolling radius of the wheel. Based on the obtained values of the real rolling radius and the initial radius of the wheel, slip coefficients at different tire pressures were calculated.

The reliability of the theoretically and experimentally obtained real rolling radius was provided by comparing the wheel slipping relative to the initial radius of the wheel.

RESULTS

To determine the actual rolling radius, the necessary parameters of the front and rear wheels were experimentally measured. A change in the tread lengths in the free state of the wheel with a change in pressure is obtained. At the accepted values of the tire stiffness coefficients, the initial radius of the wheel is calculated at the corresponding pressure in the wheel. The calculation of the actual rolling radius and the corresponding wheel slipping is also performed. Experimental and theoretical parameters when changing the front wheel pressure are performed in table 1, and for the rear wheel – in table 2.

Table 1

Experimental and theoretical parameters of the front wheel

The name and units of measurement	Symbol	Wheel pressure, atm					
		1	1.2	1.4	1.6	1.8	2
Length in the middle of the tread, m	l_C	3.875	3.88	3.88	3.885	3.885	3.89
Length at the protector edge, m	l_K	3.75	3.747	3.748	3.755	3.755	3.753
Stiffness coefficient, relative units	k_{DP}	0.92	0.91	0.9	0.89	0.865	0.845
Initial radius, m	R	0.5984	0.5982	0.5986	0.5999	0.6004	0.6006
Length of the contact zone chord, m	L	0.383	0.349	0.33	0.32	0.314	0.309
Calculated real rolling radius, m	R_D	0.5879	0.5896	0.5909	0.5926	0.5934	0.5939
Slipping, %	δ_G	1.759	1.454	1.295	1.21	1.162	1.124
Experimental real rolling radius, m	R_{DS}	0.588	0.59	0.591	0.593	0.593	0.594
Slipping, %	δ_{GS}	1.755	1.449	1.295	1.215	1.154	1.119

The dependences of the length of the wheel contact zone chord with the support surface formed by the deflection of the wheel tire on the air pressure in the tires were obtained (Fig. 2). The graph shows a tendency to reduce the length of the contact zone of the deformed wheel tire with increasing air pressure in the tires.

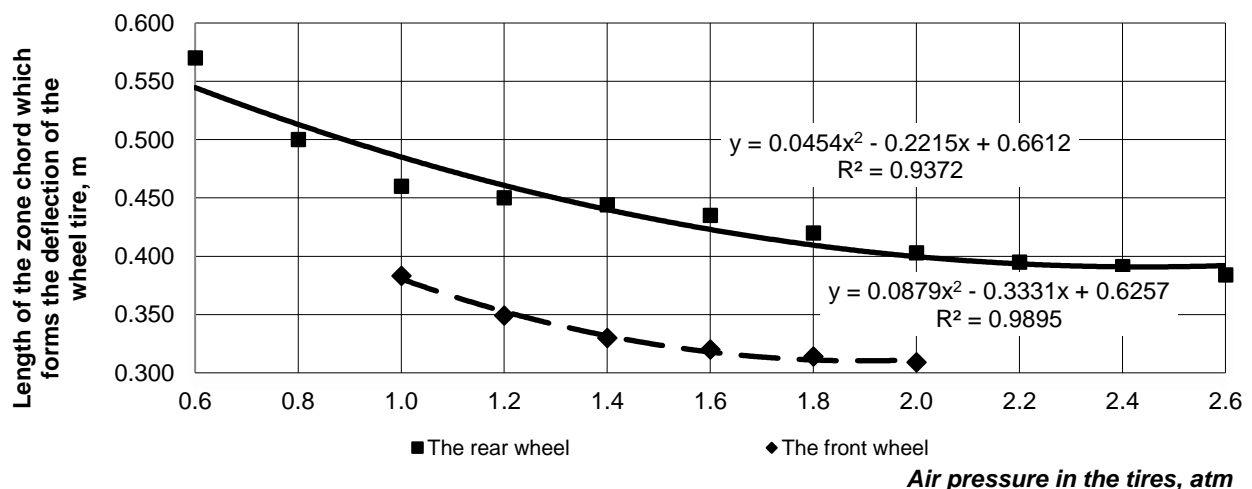

Fig. 2 - The dependence of the length of the zone chord (the length of the deformed wheel tire imprint), which forms the deflection of the wheel tire from the air pressure in the tires

Table 2

Experimental and theoretical parameters of the rear wheel

The name and units of measurement	Symbol	Wheel pressure, atm										
		0.6	0.8	1	1.2	1.4	1.6	1.8	2	2.2	2.4	2.6
Length in the middle of the tread, m	l_c	5.483	5.484	5.485	5.485	5.495	5.495	5.5	5.505	5.51	5.51	5.51
Length at the protector edge, m	l_k	5.253	5.253	5.253	5.253	5.254	5.254	5.255	5.254	5.255	5.26	5.26
Stiffness coefficient, relative units	k_{DP}	0.615	0.6	0.595	0.545	0.495	0.45	0.42	0.37	0.365	0.36	0.355
Initial radius, m	R	0.85	0.85	0.851	0.852	0.855	0.857	0.858	0.861	0.862	0.862	0.862
Length of the contact zone chord, m	L	0.57	0.5	0.46	0.45	0.444	0.435	0.42	0.403	0.395	0.391	0.384
Calculated real rolling radius, m	R_D	0.833	0.838	0.840	0.842	0.845	0.847	0.850	0.853	0.854	0.855	0.855
Slipping, %	δ_r	1.938	1.477	1.244	1.185	1.145	1.094	1.014	0.927	0.888	0.869	0.838
Real rolling radius, m	R_{DS}	0.833	0.837	0.839	0.842	0.845	0.847	0.849	0.853	0.854	0.854	0.855
Slipping, %	$\delta_{r\gamma}$	1.945	1.463	1.268	1.173	1.144	1.083	1.017	0.949	0.899	0.872	0.839

The initial radius of the wheel depending on the air pressure in the tire, calculated by the equation 8, is shown in Fig.3. The graph shows that the initial radius of the wheel increases with increasing air pressure in the tire.

Fig.4 and Fig.5 demonstrate the results of calculation and experimental measurement of changes in the actual rolling radius of the front and rear wheels, respectively, depending on changes in air pressure in the tire. The calculated real rolling radius is determined based on the length of the wheel contact zone chord and the initial radius of the wheel according to the equation 9 for the corresponding tire pressure in the wheel.

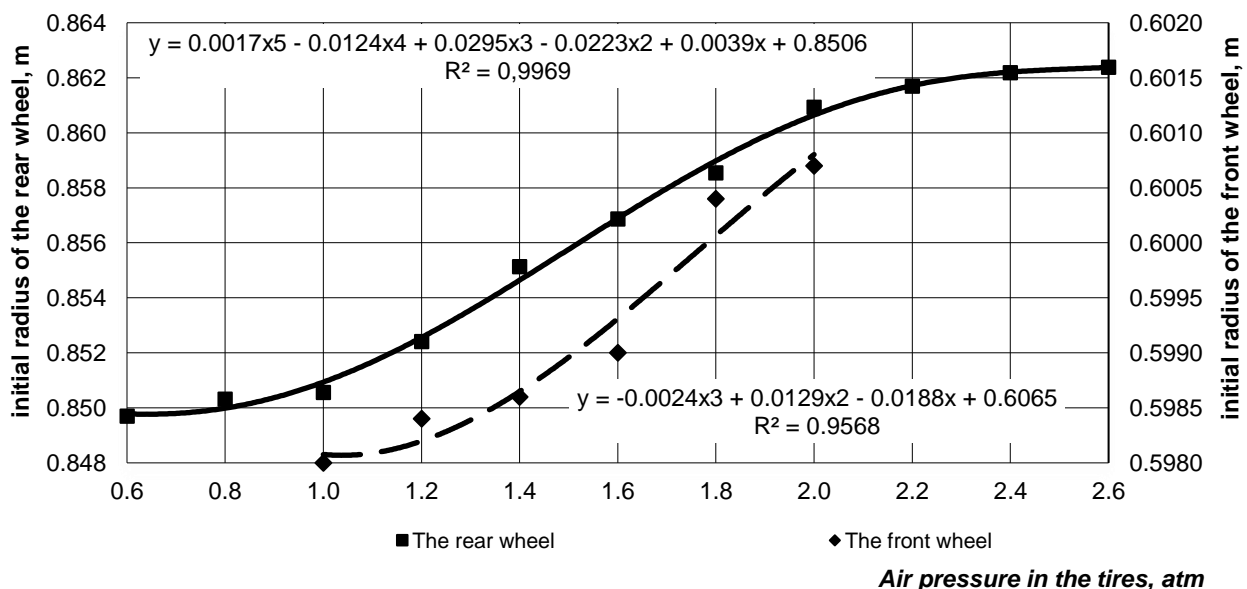

Fig. 3 - The dependence of the initial radius of the wheel, considering the deformation of the tread caused by its own weight

Analysis of the obtained dependences Fig. 4 and Fig. 5 indicates an increase in the real rolling radius with increasing air pressure in the tire. For the front wheels with an increase in pressure from 1 to 2 atm, the change in the actual rolling radius was about 7 mm for the rear wheel; the change in the actual radius was about 21 mm with a change in pressure from 0.6 to 2.6 atm. The determination index of the calculated and experimental data was $\eta^2 = 0.98$ for the front and $\eta^2 = 0.99$ for the rear wheels.

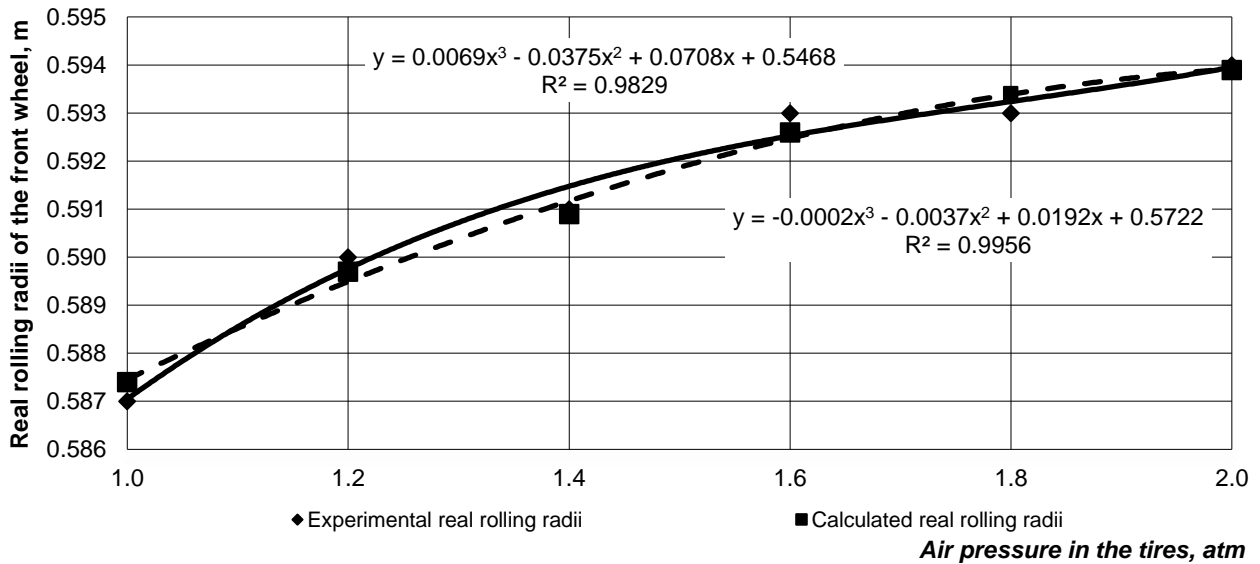

Fig. 4 - Dependences of the calculated and experimental real rolling radius of the front wheel on changes in tire air pressure

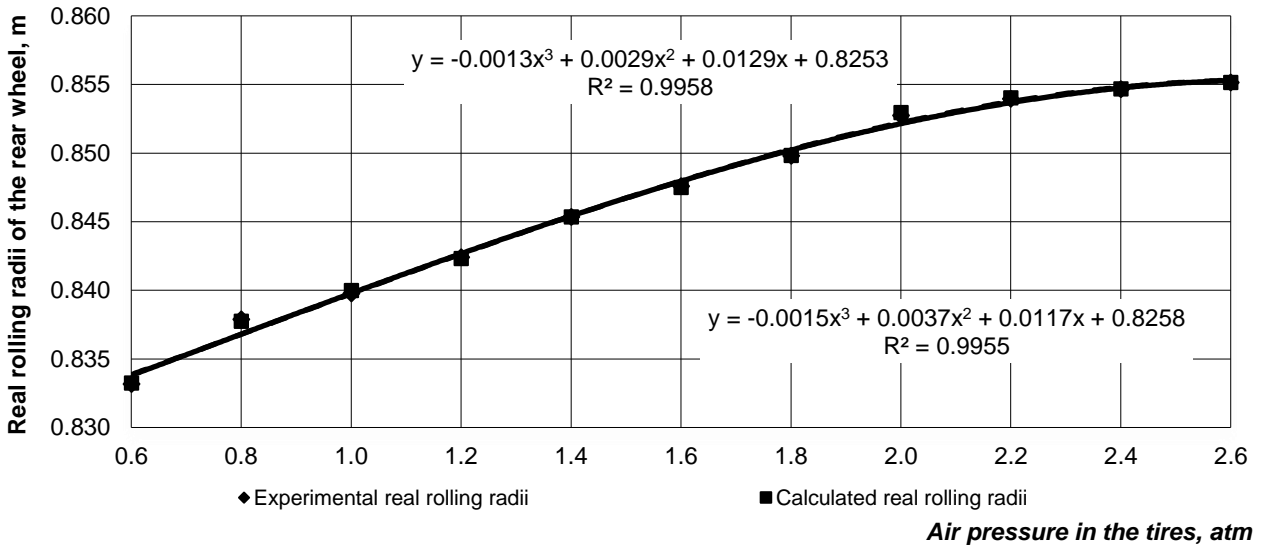

Fig. 5 - Dependences of the calculated and experimental real rolling radius of the rear wheel on changes in tire air pressure

It is also provided the calculation of the wheel slipping when changing the internal pressure of the tire (Fig. 6, 7).

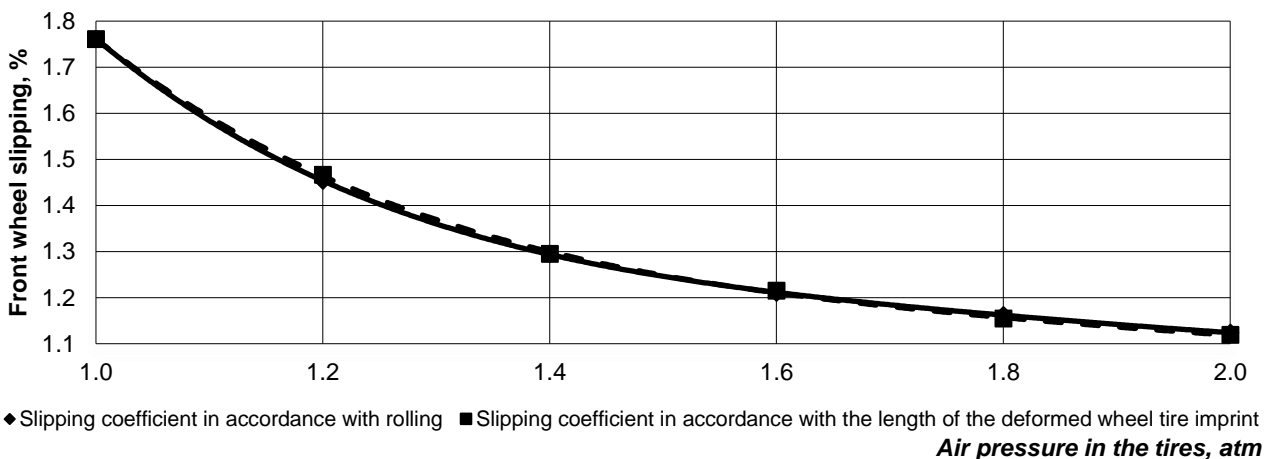

Fig. 6 - The dependence of the front wheel slipping on air pressure in tires

Thus, the calculated slipping has a value from 1.94 to 0.83% for the rear wheels, and from 1.12 to 1.76% for the front wheels. The value of the wheel slipping decreases as the air pressure in the tires increases, which is explained by a decrease in the length of the tire contact zone chord and an increase in the actual radius of rotation of the wheel relative to the initial one.

The high level of coincidence between the calculated and experimental dependences for determining the wheel slipping indicates the adequacy of the proposed method for determining the initial radius of the wheel and the actual rolling radius.

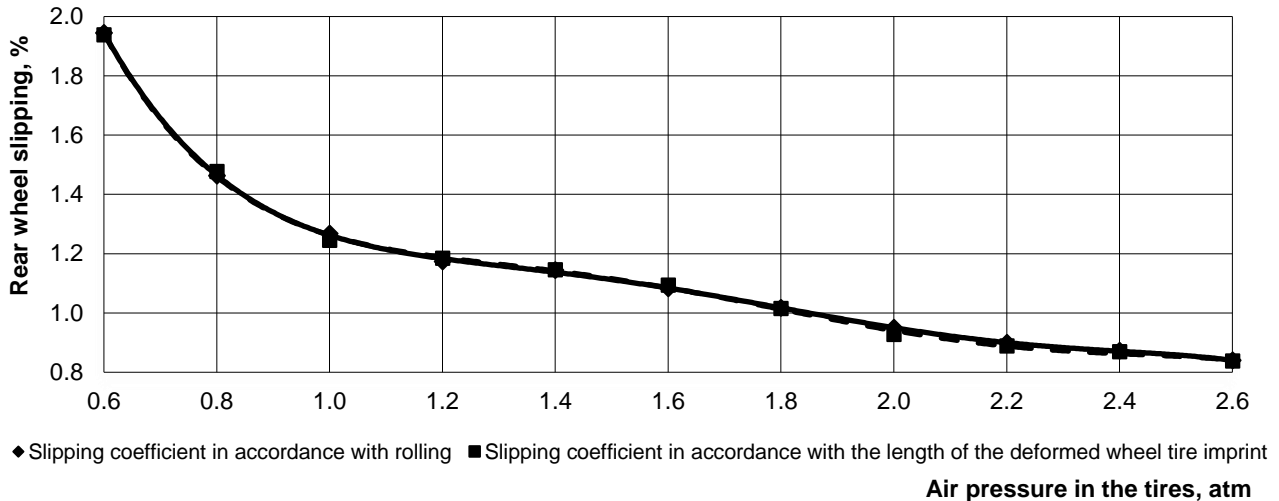

Fig. 7 - The dependence of the rear wheel slipping on air pressure in tires

As a result of the research, the principles of determining the initial radius of the wheel based on which it is possible to determine the actual radius of the wheel rolling are substantiated. The high level of coincidence between the calculated and experimental values of the actual wheel radius and wheel slipping indicates the adequacy of the developed methods and dependencies for practical application.

The obtained results allow estimating the effect of wheel deformation under the influence of vertical load (the weight of the power unit) on the actual wheel rolling radius and the wheel slipping. As long as the vertical load is constant, than the actual rolling radius and the slipping while wheel rolling can be taken for the initial state of the wheel. The initial state of the wheel allows evaluating the impact of other parameters on the wheel rolling performance, which creates the prerequisites for the development of a control system for the operation of wheel systems of self-propelled machines.

Further research is advisable to continue in the direction of determining the effect of torque on the change in wheel rolling and driving wheel slipping. The other important issue for further research is determining the nature of the stiffness coefficient of the pneumatic tire tread and determining the impact of the wheel tire design parameters on the deformation of the tread and the wheel frame.

CONCLUSIONS

1. Determining the initial radius of the wheel allows calculating the actual rolling radius of the wheel, taking into account the geometric parameters of wheel deformation in the area of contact with the support surface. The coincidence of the dependences of wheel slipping on the change of air pressure in the tire, obtained based on the calculated and experimentally determined real rolling radius, suggests that the proposed model for determining the initial radius of the wheel is adequate.

2. On the basis of the geometric parameters of the contact zone at the interaction between the wheel and the support surface, an expression for determining the actual radius of the wheel rolling is obtained. Comparison of the calculated and experimentally obtained real rolling radius of the wheel allows us to assert the adequacy of the applied technique and the obtained dependence for determining the actual rolling radius. The determination index of the calculated and experimental data is $\eta^2 = 0.98$ for the front and $\eta^2 = 0.99$ for the rear wheels.

3. The studies proved an increase in the actual rolling radius and a decrease in wheel slipping with increasing air pressure in the tire. Thus, for the rear wheel, at an increase in pressure from 0.6 to 2.6 atm, an increase in the rolling radius by 21 mm, and a decrease in the slipping from 1.94 to 0.83% are observed. For the front wheel, when the pressure changes from 1 to 2 atm, the rolling radius increases by 7 mm and the

wheel slipping decreases from 1.76 to 1.12 %. The obtained results allow evaluating the slipping of the drive wheels of power units in accordance with the air pressure in the tires and the parameters of interaction with the support surface.

REFERENCES

- [1] Bekker M.G., (1956), *Theory of land locomotion: the mechanics of vehicle mobility*, Ann Arbor: The Univ. Michigan Press., 522 p., USA;
- [2] Dwyer M.J., Comely D.R., Evernden D.W., (1974), The field performance of some tractor tyres related to soil mechanical properties, *Journal of Agricultural Engineering Research*, Vol. 19, ISSN: 00218634, pp. 35–50;
- [3] Golub G., Chuba V., Kukharets S., (2017), Determining the magnitude of traction force on the axes of drive wheels of self-propelled machines, *Eastern European Journal of Enterprise Technologies*, Vol. 4 (7), ISSN: 17293774, pp. 50-56;
- [4] Gray J.P., Vantsevich V.V., Paldan J., (2016), Agile tire slippage dynamics for radical enhancement of vehicle mobility, *Journal of Terramechanics*, Vol. 65, ISSN: 00224898, pp. 14-37;
- [5] Hamersma H.A., Botha T.R., Schalk Els.P., (2016), The dynamic rolling radius of a pneumatic tyre on hard terrains, *18th International Conference of the ISTVS, International Journal of Vehicle Systems Modelling and Testing*, Vol 11 (3), ISSN: 17456436, pp. 234-251;
- [6] Huang X., Wang J., (2013), Centre of gravity height real-time estimation for lightweight vehicles using tire instant effective radius, *Control Engineering Practice*, Vol. 21 (4), ISSN: 09670661, pp. 370-380;
- [7] Jazar R. N., (2017), *Vehicle dynamics: Theory and application*, Springer, Cham, ISSN: 978-3-319-53440-4, 985 p, USA;
- [8] Kiss P., (2003), Rolling Radii of a Pneumatic Tyre on Deformable Soil, *Biosystems Engineering*, Vol. 85, ISSN: 15375110, pp. 153-161;
- [9] M'Sirdi N.K., Rabhi A., Fridman L., Davila J., Delanne Y., (2008), Second order sliding-mode observer for estimation of vehicle dynamic parameters, *International Journal of Vehicle Design*, Vol. 48, ISSN: 01433369, pp. 190-207;
- [10] Pauwelussen J.P., Dalhuijsen W., Merts M., (2007), *Tyre dynamics, tyre as a vehicle component, Virtual Education in Rubber Technology (VERT)*. HAN University, http://laroverket.com/wp-content/uploads/2015/03/tyre_as_car_component.pdf;
- [11] Rubinstein D., Shmulevich I., Frenkel N., (2018), Use of explicit finite-element formulation to predict the rolling radius and slip of an agricultural tire during travel over loose soil, *Journal of Terramechanics*, Vol. 80, ISSN: 00224898, pp. 1-9;
- [12] Ryan J., Bevy D., (2012), Tire radius determination and pressure loss detection using GPS and vehicle stability control sensors, *IFAC Proceedings Volumes 8th IFAC Symposium on Fault Detection, Supervision and Safety of Technical Processes*, Vol 8 (1), ISSN: 14746670, pp. 1203-1208;
- [13] Sabatini S., Formentin S., Panzani G., Santos J.D.-J.L., Savaresi S.M., (2017), Motorcycle tire rolling radius estimation for TPMS applications via GPS sensing, *1st Annual IEEE Conference on Control Technology and Applications*, ISBN: 978-150902182-6, pp. 1892-1897;
- [14] Taghavifar H., Mardani A., (2014), Applying a supervised ANN (artificial neural network) approach to the prognostication of driven wheel energy efficiency indices, *Energy*, Vol. 68, ISSN: 03605442, pp. 651-657;
- [15] Taghavifar H., Mardani A., (2015), Net traction of a driven wheel as affected by slippage, velocity and wheel load, *Journal of the Saudi Society of Agricultural Sciences*, Vol. 14, 167–171;
- [16] Tannoury C. El., Plestan C., Moussaoui F., Romani N., (2011), Tyre effective radius and vehicle velocity estimation: A variable structure observer solution, *Eighth International Multi-Conference on Systems, Signals and Devices.*, ISBN: 978-1-4577-0413-0, pp. 1-6;
- [17] Upadhyaya S., Chancellor W. Wulfsohn D., (1988), Sources of variability in traction data, *Journal of terramechanics*, Vol. 25 (4), ISSN: 00224898, pp. 249-272;
- [18] Wilson T., Siero M., Kopchick C., Vantsevich V., (2011), Rotational Velocities and Tire Slippages, *SAE Technical Paper*, ISSN 0148-7191, 2011-01-2157;
- [19] ***ASABE Standards, (2013) General Terminology for Traction of Agricultural Traction and Transport Devices and Vehicles. ASABE Standards s296.5.