

We are IntechOpen, the world's leading publisher of Open Access books Built by scientists, for scientists

4,500

Open access books available

119,000

International authors and editors

135M

Downloads

Our authors are among the

154

Countries delivered to

TOP 1%

most cited scientists

12.2%

Contributors from top 500 universities



WEB OF SCIENCE™

Selection of our books indexed in the Book Citation Index
in Web of Science™ Core Collection (BKCI)

Interested in publishing with us?
Contact book.department@intechopen.com

Numbers displayed above are based on latest data collected.
For more information visit www.intechopen.com



Study of the Electromagnetic Radiation on the Animal Body

Leonid Chervinsky

Abstract

The rapid technical development of human society on Earth leads to the pollution of its atmosphere and an increase in the electromagnetic radiation of the Sun and its main part—light and ultraviolet radiation. In order to properly protect and control the effects of electromagnetic radiation on the human body, it is necessary to know and understand the process of absorption and conversion of electromagnetic radiation falling on the surface of the body. The material contains the original results of experimental studies on electromagnetic radiation transmission through a sample of quasi-vital skin with pigs of different ages. The reliable results of the percentage ratio of the amount of electromagnetic radiation of the optical spectrum that passes under the skin through the skin layer and the individual wool depending on the species and age of the animal are obtained. The results of the experiment showed that the electromagnetic radiation of the Sun affects the body of the animal through the skin, as well as inside the cylinders of separate wool. This new knowledge is important for biologists and applied engineers to monitor and control electromagnetic radiation for young and old animals with different wools.

Keywords: electromagnetic radiation, transmission, reflection, scattering and absorption, skin, animal body surface, conductivity, separate wool

1. Introduction

In life, when a person or an animal is under the influence of electromagnetic radiation of the Sun or a special source of electromagnetic radiation of different spectral composition, the biological effect causes radiation energy to enter the surface of its body.

The human body is covered with clothes. The body of the animal is protected by different hairs or wools. It is known that the electromagnetic radiation of the optical spectrum of the short wavelength range (ultraviolet radiation) is very active in the body. Therefore, it is of scientific interest to study the penetration of optical radiation of different wavelengths (spectrum) into the human and animal body. Experimental studies were carried out quickly on the skin with the hair of recently dead animals. The results of such studies are presented below in the described material.

2. Methods and installation for studying the paths of penetration of optical and, in particular, ultraviolet radiation into the animal's body

According to the law of geometric optics, the interaction of the optical radiation with the irradiated biological object is characterized by the spectral optical

absorption coefficients $\alpha(\lambda)$, the reflection $\rho(\lambda)$, and the transmission $\tau(\lambda)$, which are interconnected by the dependence (1):

$$\alpha(\lambda) + \tau(\lambda) + \rho(\lambda) = 1 \quad (1)$$

Measurement of spectral optical characteristics (absorption coefficients $\alpha(\lambda)$, reflection $\rho(\lambda)$, and transmission $\tau(\lambda)$) in the cover of animals is associated with the difficulties of the methodological and technical capabilities in the formation of the experiment.

Firstly, there is a large discrepancy in the magnitude of the coefficients. Based on the analysis of the literature [1, 2] and the results of our own research [3–5], it was found that the magnitude of the reflection coefficients of optical radiation for the shelter of animals is within 0.10–0.60 incident radiation and the transmittance is less than 0.05–0.00001 incident radiation (depending on the thickness of the coating and body pigmentation). Using one method and device measures is impossible without large errors. Therefore, for their measurements, use different methods and different technical devices.

Secondly, the measurement of the optical coefficients of individual skin and wool is associated with similar difficulties due to the large difference in the geometric dimensions of the samples studied: the cross-sectional area of an individual wool has an order of magnitude 0.01 mm^2 , the area of the skin between the individual hairs is 1 mm^2 , and the area of irradiation of the skin and wool is regulated by the size of the animal (about 1 m^2), and therefore various technical means are used to measure them.

Thirdly, in the system research of the spectrum of optical radiation, there is a need for variable optical systems. In order to increase the flux of the intensity of incident or measured radiation (thus increasing the accuracy of the measurement), the focusing optical systems are used in the studies, which, unfortunately, have different degrees of transparency for different sections of the optical radiation spectrum. So, for the measurement of ultraviolet radiation, optics are used from crystal glass and for visible radiation, from “ordinary” glass, and for infrared radiation, from a special high-temperature quartz glass.

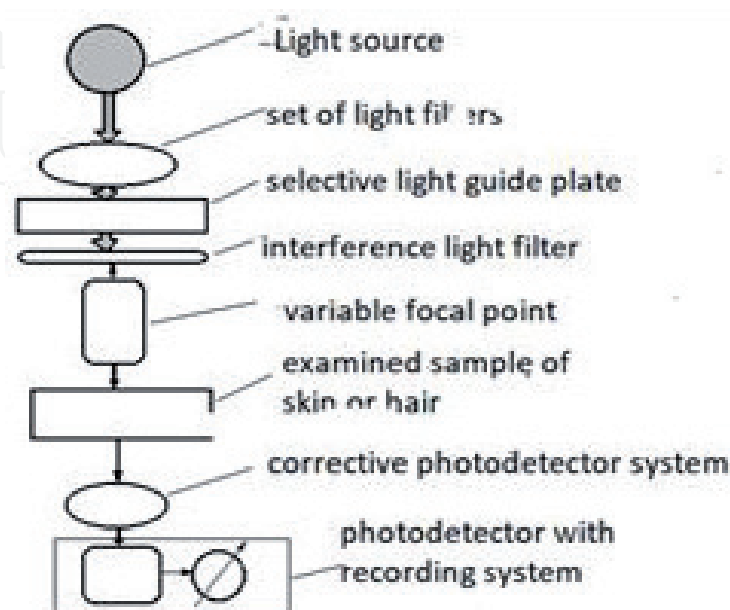

Figure 1. The block diagram of the installation for the investigation of spectral optical characteristics of the cover of animals.

Our long-term research in this area has allowed us to develop a method for determining all the named spectral coefficients of the skin and animal wool and the creation of a universal installation for measuring spectral optical coefficients based on a universal fluorescent microscope LUMAM-I3 (Russia) (<http://www.laboratorium.dp.ua/item/53>).

The structural-optical scheme of the universal device for the study of the optical characteristics of individual wool, areas of clear skin, and areas of the skin with wool is shown in **Figure 1**.

Determination of the spectral coefficients of absorption, reflection, and transmission of the skin and wool cover and its components in animals of different species, age, and breed was summarized on this research facility, made on the basis of the universal luminescent microscope “LUMAM-I3.”

The versatility of the proposed installation lies in the fact that the shift of focusing lenses allows you to focus on the irradiation beam (cut from the flow of the optical radiation from the source by a system of quartz and interference filter system) on the plane of the investigated object micro- and macrosize of the area: from 1 cm² to 0.01 mm². In this case, the sensitivity of the photodetector by the corrective optical system is regulated in the range from 0.01 mW/mm² to 1 W/mm² and takes into account its selective sensitivity to the radiation spectrum. Due to this, it is possible to conduct structural investigations of optical characteristics in the same direction at the same installation:

- Study of optical characteristics of large areas of skin with a wool
- Study of optical characteristics of skin micro areas between individual wools
- Study of optical characteristics and light conductivity of individual wool in animals of all ages and species

It is important that as a result of the study of the optical characteristics and their analysis, it is possible to determine the quantitative scheme of the distribution of electromagnetic radiation parts of the optical spectrum penetrating the skin separately through the skin, through the cylinder separate wool, and as a whole through leather and wool.

In order to increase the reliability of the results obtained in the experiments of measuring the radiation flux from the source was carried out with the help of a photoelectron multiplier, the signal from which was perceived through an amplifier with a sensitive galvanometer, or the corresponding interface through an analog-digital converter was fed for mathematical processing on a computer.

Meanwhile, the measurements of the measuring galvanometer have always been directly proportional to the flux emitted by the photomultiplier (the condition was satisfied so that the intensity of the radiation flux coming into the perimeter window of the photomultiplier was within the linear section of its sensitivity characteristic).

This condition allowed for the calculation of optical coefficients to accurately determine the relative radiation flux through the indicators of the galvanometer, and not in energy units.

In particular, the transmission coefficients of the optical radiation in the investigated samples were determined by the formula (2):

$$\tau_{\lambda} = \frac{I_{\lambda}}{I_{0\lambda}} \quad (2)$$

where I_{λ} is the photocurrent in measuring the radiation flux with wavelength λ passing through the sample (μA) and $I_{0\lambda}$ is the photocurrent in measuring the

radiation flux with wavelength λ from the source supplied to the photomultiplier without a sample (μA).

If, in studies, the value of the photocurrent after passing through the sample is much smaller than the photocurrent from the source, $I_\lambda \ll I_{o\lambda}$, observed in studies with short-wave ultraviolet radiation at wavelengths less than 365 nm from powerful sources of ultraviolet radiation (due to strong absorption in the irradiation), in the measurement, an error is introduced due to the over-excitation of the photodetector by powerful radiation, and therefore, we have a decrease in its sensitivity (due to the outflow of the linear portion of its h sensitivity characteristics).

To eliminate such an effect, the magnitude of the excitatory radiation from the source was measured by the use of radiation absorbents (nonselective dimming filters of the type NS) with a known attenuation coefficient.

In the described studies, the expression for determining the spectral coefficients of optical transmission has the formula (3):

$$\tau_\lambda = \frac{I_\lambda \cdot \tau_{\lambda\phi}}{I_{o\lambda\phi}} \quad (3)$$

where I_λ is the photocurrent in measuring the radiation flux with wavelength λ passing through the sample (μA); $\tau_{\lambda\phi}$ is the transmission coefficient of a neutral filter; and $I_{o\lambda\phi}$ is the photocurrent in measuring radiation emitted with wavelength λ by the photodetector through a dimming filter (μA).

An important optical parameter is also the reflection coefficient of optical radiation from the formula (4):

$$\rho_\lambda = \frac{I_\lambda - I'_\lambda}{I_{\lambda e} - I'_\lambda} \cdot \rho_{\lambda e} \quad (4)$$

where I_λ is the photocurrent in measuring radiation reflected from the sample (μA); I_λ is the photocurrent in the measurement of radiation, with a wavelength λ reflected from the standard (μA); I'_λ is the extraneous current that shows the galvanometer in the absence of the sample and reference (μA); and $\rho_{\lambda e}$ is the reflection coefficient of radiation with wavelength λ , for the standard.

A standard used that is commonly accepted in optical studies is the metal plate with a precipitated layer of sulfuric acid barium. The sulfuric acid barium has a comparatively identical reflection coefficient for optical radiation in the range of 640–250 nm equal to 0.96–0.98 [1].

The last important absorption coefficient of optical radiation by the sample was determined by the known formula (1):

$$\alpha_\lambda = 1 - \rho_\lambda - \tau_\lambda \quad (5)$$

It is important to recognize that when measuring the spectral reflection coefficients in the UV region, along with reflected radiation, the radiation of long-wave luminescence of the objects under investigation, which originated from this ultraviolet radiation, was recorded. This radiation made an additional error in the magnitude of the reflection coefficients, but the error introduced did not have a significant effect (given that the intensity of the luminescence was 10n times less than the intensity of the reflected radiation).

The results obtained by this method, the results of the optical characteristics of the skin samples with the wool of different species of animals, and their analysis allow us to determine the quantitative scheme of the distribution of optical radiation penetrating under the skin separately through the skin itself, by individual wool, and are generalized through the leather and wool cover [7–9].

Methods of mathematical statistics are used to process experimental results with given accuracy and reliability. In the processing of experimental data, gross errors were removed from the series. Measurement of optical and electrical quantities was performed at least three times, and the average value of the measured value was analyzed. The variance, coefficient of variation, and mean square deviation of the obtained data were determined.

3. Investigation of the light conductivity of individual wool from pigs

In studies devoted to the study of the laws of penetration of optical radiation through the wool coating of animals, the possibility of penetration of radiation under the skin by individual wool, as in fibers, was studied. The main objects were the wool (bristles) of pigs. The choice is based on the fact that pigs' wool has the largest cross-sectional area among other farm animals, and the radiation that passes through the wool cylinder to the photomultiplier tube makes it a valid signal in the linear part of its sensitivity profile.

That is, the value of the photocurrent is greater than the sensitivity threshold of the photoelectron multiplier. This fact increases the reliability of the measurement results. The study scheme is shown in **Figure 2**.

To determine the spectral coefficients of optical conductivity, a system of interference filters with a bandwidth of 10 nm in the range from 300 to 760 nm was used. The corrective lens system is used to ensure uniform irradiation of the sensing area of the sensitive surface of the photo-measuring sensor. To ensure the purity of the study, a rubber seal was applied to the skin from above, in which a separate wool was passed through the hole. The radiation flux was focused on the wool surface above the seal, and the radiation that passed through its cylinder under the skin was recorded.

Then the wool was cut off over the compaction (the radiation was directed perpendicular to the surface of the trimmed hair) and, finally, cut off the follicular

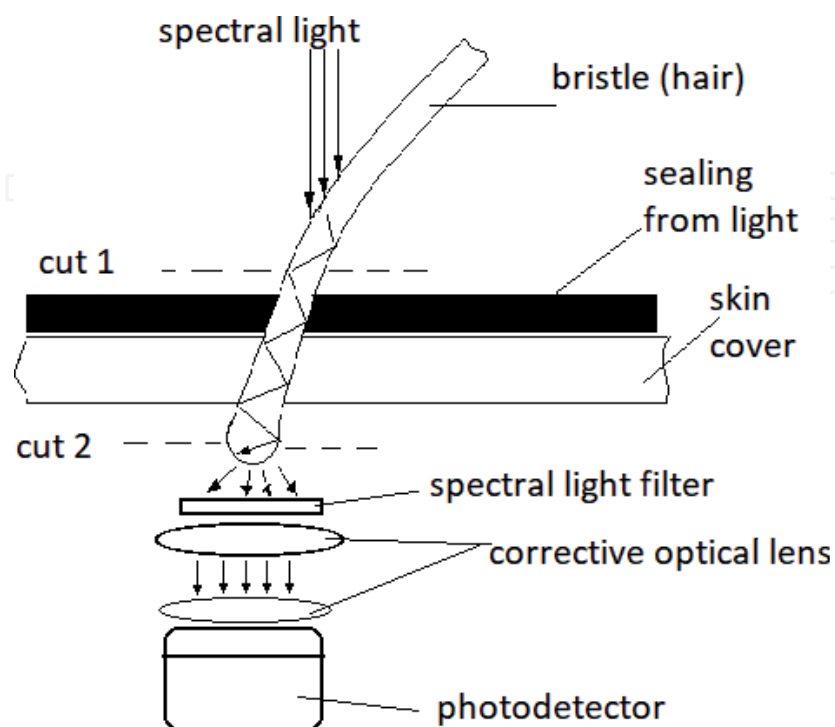

Figure 2.
The structure of the installation for the study of the penetration of electromagnetic radiation of the optical spectrum by a separate cylinder of wool under the skin.

sphere from the lower part of the skin. Registration of the radiation flux under the skin was carried out in stages, both visually and using a photo-measuring device. **Figure 3** shows the correct results of studying the optical conductivity of individual wool in light pigs (Landrace, Large White).

Analysis of the data shows that white wool conducts up to 10% of the visible electromagnetic radiation falling from above on its surface, depending on the diameter and structure of the wool. When the hair is trimmed over the skin, the radiation emitted into the subcutaneous structure increases. The results of experimental studies of the passage of optical radiation in the cylinder of an individual hair under the skin, on samples of the skin with hair from Large White pigs of different ages, are shown in **Table 1**.

From the tabular data, it can be seen that clipping the sphere of the follicle of an individual wool several times increases the value of the measured radiation. This indicates that the follicle sphere dissipates and absorbs part of the radiation energy (turns into another), that is, the follicle is the particular basis of the photobiological reaction. Practical confirmation of this fact is important for further understanding of the mechanism of penetration of optical radiation into the animal's body and its place of interaction with the biological structures of the skin.

A visual observation of an experiment on the transmission of optical radiation under the skin for different animals (when irradiating a part of the skin surface with wool) also revealed that the follicles have a brighter glow than the inner surface of the skin. Therefore, it is permissible to assert that follicles can be considered as light bulbs in the skin structure and, consequently, primary cells of active photobiological reactions. And there is a realistic explanation: the energy of optical radiation, which reaches the follicles inside the wool cylinder, directly affects the biologically active structures (nerve and blood principles that supply the necessary bioproducts for the formation and growth of wool) and causes a greater photobiological effect than the radiation that passes at the same depth under the skin between individual wool and reaches less active biological entities in the structure of the skin itself [2, 5]. This path is also important because of the fact that the energy of optical radiation enters the wool under the skin directly to the follicle unchanged. In the immediate proximity of the follicle are salogen and sweat glands filled with reactive cellular organic components.

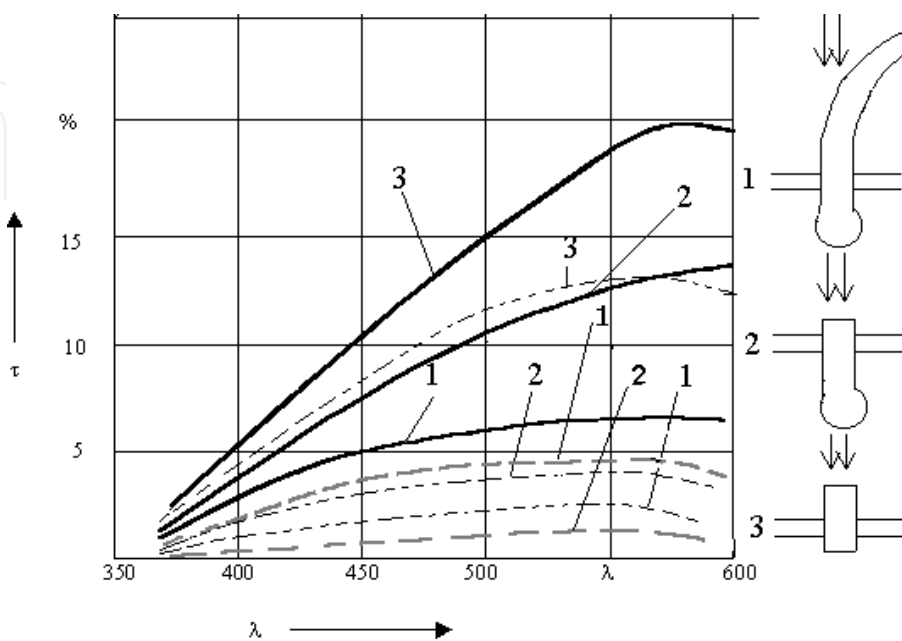

Figure 3. Spectral coefficients of transmission of a wool and its segments, at a cross section of a wool: — $S = 0.12 \text{ mm}^2$, - - $S = 0.08 \text{ mm}^2$, _ _ $S = 0.062 \text{ mm}^2$.

Age of animals	Thickness skin, mm	Cross section of the wool, mm ²	Wool length (to the cut), mm	Follicles	Light conductivity, μA
3 years	3.5	0.11–0.13	Whole wool	Is	12–14
3 years	3.5	0.11–0.13	2.6–2.8 [*]	Is	24–28
3 years	3.5	0.11–0.13	2.6–2.8 [*]	The cut	74–90
12 months	2.3	0.085 × 0.09	Whole wool	Is	9–12
12 months	2.3	0.085 × 0.09	2.6–2.8 [*]	Is	20–25
12 months	2.3	0.085 × 0.09	2.6–2.8 [*]	The cut	52–76
8 months	2.0	0.07–0.074	Whole wool	Is	4–7
8 months	2.0	0.07–0.074	2.6–2.8 [*]	Is	10–12
8 months	2.0	0.07–0.074	2.6–2.8 [*]	The cut	26–34

^{*}The length of the wool segment was measured from the cut above the rubber seal to the surface of the skin.

Table 1.
 The results of experimental studies of the light conductivity of a single wool under the skin of an animal.

The suitability of this assumption is confirmed by the results of biochemical studies of the effect of optical radiation on the skin, carried out by other authors [3, 5].

To obtain a three-coordinate model describing the spectral dependence of the transmission of electromagnetic radiation on the optical spectrum of a single-cylinder hair on its length, a multiple regression analysis of experimental data was carried out in the Mathcad 2001 Pro software environment. The result of the study is shown in **Figure 4**.

It can be seen from the above that, with the decrease in the wavelength of the optical radiation falling on the surface of a separate one wool, its light conductivity decreases. This corresponds to the results obtained by other authors [2, 4].

The established fact of the propagation of optical radiation energy inside a single-haired cylinder allows determining the intensity of the electromagnetic radiation of the optical spectrum at a specific location of wool (e.g., at the place where it appears above the skin, or at the growth site from the follicle), depending on the distance to the fall site radiation to the surface of a single layer, which is important to know in biological studies when studying the mechanism of the action

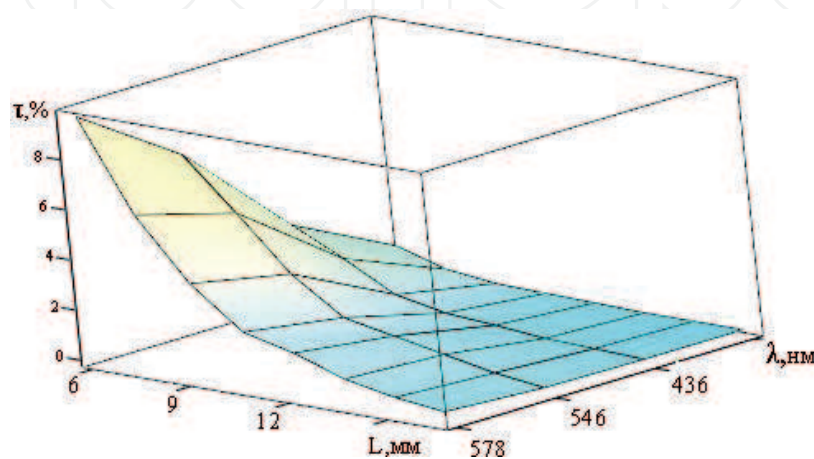

Figure 4.
 The dependence of the coefficient transmission of a separate cotton wool τ from the spectral composition of the electromagnetic radiation λ and the length of its light-conducting part L (distance to its follicle).

of optical radiation through the skin and wools on an animal's body in order to make the desired effective dose and control its effects.

For the visual confirmation of the light conductivity of the wool of different species of animals, the study of the light conductivity of individual wools was carried out by the method of photographing.

The photographs were taken according to the above scheme on **Figure 5**.

Figure 6 shows an example of a photo of the light transmission of the wool of different animals.

Photo analysis shows that pet hair is mostly transparent to visible radiation. The coat of natural animals is darker with respect to visible radiation. This is natural because wildlife is much more exposed to the open environment and longer exposed

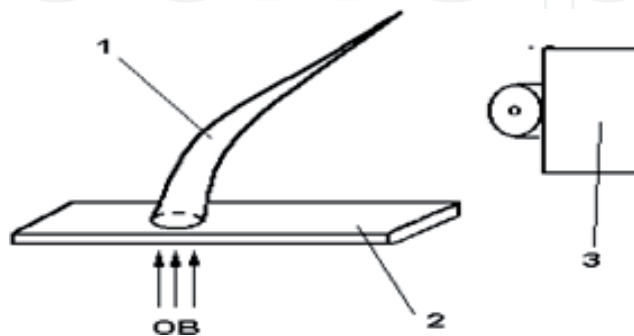

Figure 5.
Scheme for photographing the light conductivity of a single wool. 1, wool; 2, seals; 3, camera; OB, optical radiation.

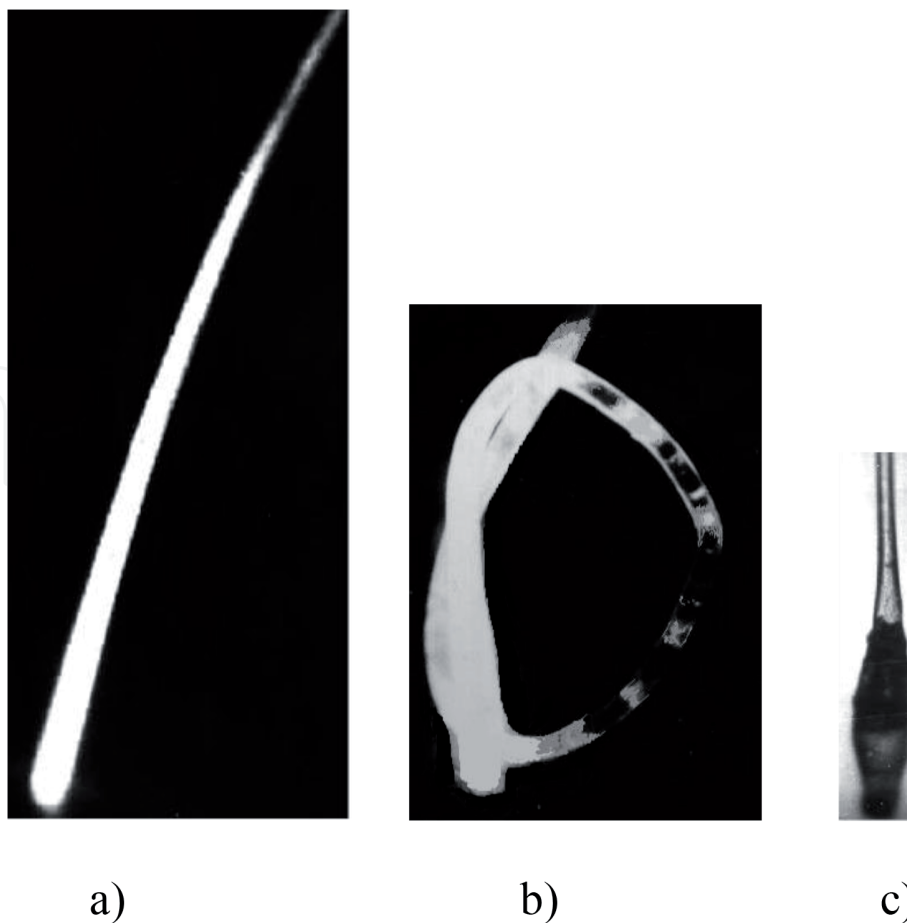

Figure 6.
Photos of the light conductivity of single wools from different animals: (a) horse tail, (b) wool of pigs, and (c) of the one wools' follicle.

to sunlight. In summer, when there are long days and intense sunlight, most wild animals have a dark coat color to protect against excessive radiation; in winter, most animals “melt,” turning their wool into lighter and thicker ones, which protects from cold and contributes to a wider use of heat when there is less solar radiation in summer.

The calculations presented further confirm that the wool coating plays a significant role in the transfer of the energy of optical radiation of an animal’s organism (especially in domestic animals that genetically experience the need for solar radiation under cultivation in a closed space) due to better conductivity and also due to the transfer of energy of this radiation directly to biologically active centers in the skin.

4. Investigation of optical characteristics of skin and wool cover animals

Given the biological significance of radiation that reaches subcutaneous body structures directly on individual wool, it should be noted that under natural conditions biological action results in radiation that passes under the skin in any way and reaches active structures. Therefore, it is also important to know what proportion of the energy of optical radiation falling on the surface of the animal passes directly through the skin. For this purpose, complex studies were conducted on samples of the skin with wool, in which the radiation was focused on the areas of the skin between the hairs in accordance with the scheme shown in **Figure 1**.

Based on the results of experimental studies, the generalized curves of the spectral transmittance of optical radiation versus skin thickness for animals of light breeds are shown in **Figure 7**.

For animals listed in **Table 1**, the coefficients of complete transmission of electromagnetic radiation of the visible spectrum of the skin with an area of 1 cm^2 were investigated. The three-coordinate **Figure 8** shows, after mathematical processing and generalization of the experimental data, the results of studies of the dependence of the total transmittance of skin samples with wool for the radiation of optical spectral radiation and the thickness of the animal skin.

Figure 8 shows that in the spectral range of the ultraviolet and visible areas of optical radiation with a decrease in the wavelength of radiation, the intensity and

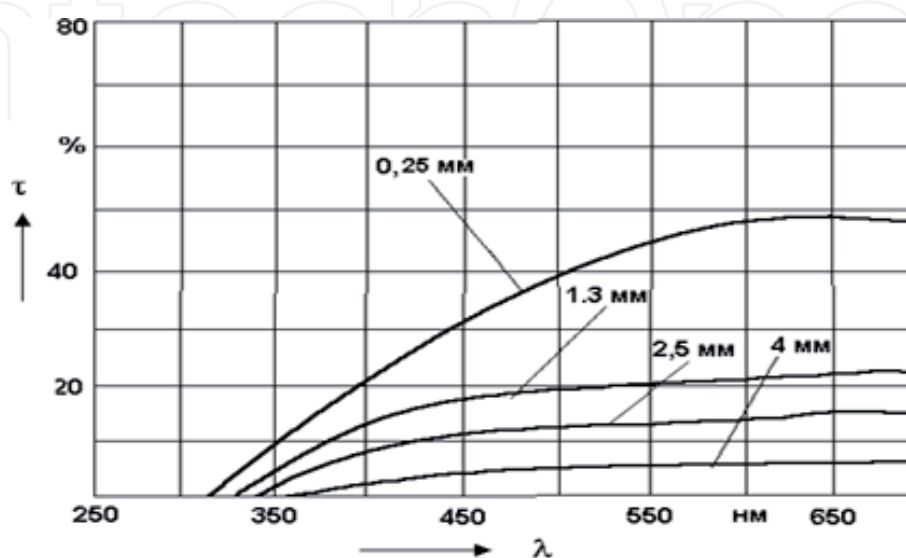

Figure 7. The transmission coefficient of electromagnetic optical radiation τ through only the skin of agricultural animals of breeds depending on the wavelength λ . Note: the skin thickness is indicated on the curves.

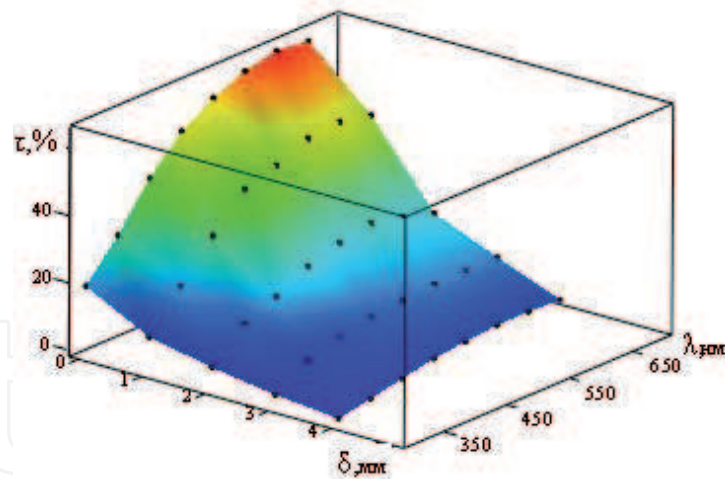

Figure 8.

Three-coordinate picture of the transmission τ of the spectrum of optical radiation to the depth of the skin and wool of the animal, depending on the wavelength of optical radiation λ and the thickness of the cover δ .

depth of penetration of its energy into the thickness of the leather and wools of farm animals decrease, which corresponds to the results of studies of other scientist experimenters.

5. Investigation of the percentage efficiency of radiation penetration through the structure of the coating (through the skin and the wool cylinders) into the animal's body

Establishing the fact of transmission of the electromagnetic radiation of the optical spectrum of an individual wool into the depths of the animal's body, together with the transmission of radiation through the entire skin and coat, is important for understanding and developing research on the mechanism of the action of electromagnetic radiation on the animal and possibly humans. As shown above, electromagnetic radiation on a separate cotton wool with its initial growth (follicle) more effectively affects subcutaneous biological structures than radiation penetrating the skin through the thickness, since the follicle has a well-developed network for the life of the blood vessels and nerve endings.

In the immediate vicinity of the follicle are sebaceous and sweat glands, filled with reactive organic secretions, and it is easy for them to consume the energy of absorbed radiation from the follicles themselves for the development of the skin and body [5].

Although the individual wool in the body of the animal comes a smaller amount of electromagnetic radiation of the optical spectrum than through the skin between the one wool, it comes directly to the biologically active components of the body cells of the animal and can have a greater effect on the photobiological reactions of its development.

In accordance with the foregoing, it is important to know how much of the optical radiation affects the body of an animal through the surface of the skin and how much it passes through individual wools (one wool). To do this, it is necessary to conduct quite complex experimental studies. The difficulty is that it is necessary to irradiate only a certain micro part of the skin surface (or individual wool) and measure the scattered radiation of low intensity that has penetrated deep into the skin.

That is, it is necessary to have a powerful source of optical radiation with a focusing system, and to measure the penetration of the radiation, a photodetector

with a perceptual window should be used with dimensions corresponding to the dimensions of the irradiated surface (to reduce the error of measurements from scattering of radiation into skin structures), or to use a complex optical integrated system that further reduces the sensitivity of the instrument (accuracy of measurements). Below is a specific example of the method of comparative analysis of the intensity of the penetration of optical radiation through the skin and on individual wool.

The criterion for the radiation flux passed into the subcutaneous layers of the animal is taken by the photocurrent of the measuring device, since the value of the photocurrent is directly proportional to the intensity of the radiation coming to the receiving window of the photo registration element. Comparison of light conductivity is carried out for a skin area of 1 mm^2 , and the conditional wool of the same section, 1 mm^2 . The relative photocurrent values for comparison are determined from formula (6):

$$I_{sk} = \frac{I_{0sk}}{S_{sk}}, I_w = \frac{I_{0w}}{S_w} \quad (6)$$

where I_{0sk} is the value of the photocurrent from the radiation that passed through the skin to the photodiode's receiving window (impressions of the experiment), S_{sk} is the area of the skin from which the penetrating radiation was recorded, I_{0w} is the magnitude of the photocurrent from the radiation that passed inside the cylinder of a single wool on the photodiode receiving window (impressions of the experiment), and S_w is the area of the cross section of a single wool from which the penetrating radiation was recorded.

The results of research and calculations for comparing the pure transmission of electromagnetic radiation of wool and skin thickness are presented in **Table 2**.

The relative transmittance of electromagnetic radiation of the solar spectrum is determined to understand the change in the quantitative ratio between the penetration of electromagnetic radiation through the skin and through a separate layer of wool during the growth of an animal according to formula (6):

$$k_c = \frac{I_w}{I_{sk}} \quad (7)$$

Based on the data in **Table 2**, a curve was constructed for seeing the change in the relative transmission coefficient of electromagnetic radiation into the animal's body with age, given in **Figure 9**.

Age, month	Light conductance and geometric parameters of pigs						
	Skin			Single wool			
	$\delta, \text{ mm}$	$S_{sk}, \text{ mm}^2$	$I_{0sk}, \mu\text{A}$	$I_{sk}, \mu\text{A}/\text{mm}^2$	$S_w, \text{ mm}^2$	$I_{0w}, 10^{-3} \mu\text{A}$	$I_w, \mu\text{A}/\text{mm}^2$
36	4 ± 0.2	5.0	3.8 ± 0.4	0.76 ± 0.08	0.03 ± 0.006	48 ± 3	1.6 ± 0.2
24	3 ± 0.4	5.0	4 ± 0.4	0.8 ± 0.08	0.025 ± 0.005	36 ± 3	1.44 ± 0.2
12	2.8 ± 0.3	5.0	5 ± 0.4	1.0 ± 0.08	0.016 ± 0.004	22 ± 3	1.35 ± 0.2
8	1.8 ± 0.2	5.0	5.8 ± 0.4	1.16 ± 0.08	0.01 ± 0.003	12 ± 3	1.2 ± 0.2

Note: δ is the thickness of the skin where the radiation was measured.

Table 2.
 Comparison table of skin transmittance and a separate wool with increasing age in an animal of a Large White breed of pigs.

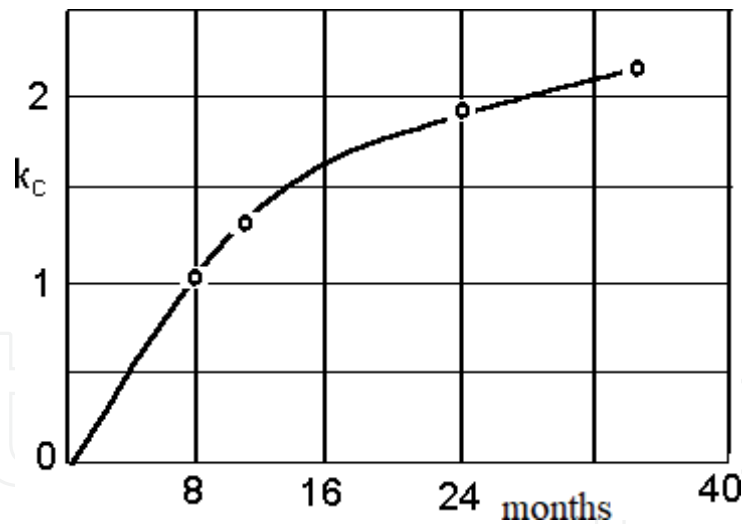

Figure 9.

Change of the relative efficiency of penetration of electromagnetic radiation of the optical spectrum under the skin of an animal by individual wool and through the skin during the growth of the animal (on the example of a White pig).

From the figure, it is clear that if the animal grows, then the skin becomes coarse and wool cylinders become thicker. This means that older animals have more efficient energy that passes through individual wools.

The analysis of the results of experimental studies shows that the working hypothesis in the process of animal development, the role of wool and skin changes in the interaction of an animal with the environment is real:

1. In young animals, the skin is thin and easily permeable to optical radiation. Therefore, it is natural that the role of the protective screen is woolen, which consists of a thick layer of thin worsted. This layer reduces the flow of optical radiation to the skin by absorbing or dispersing it into the environment and protects the young animal from excessive light energy.
2. With the development of the animal, its skin thickens, its surface and thickness increase, and the penetrating ability of the skin for optical radiation decreases; therefore, the role of the wool as a network of light conductors increases: the distance between them increases on the skin (they are less overlapping each other), their value per unit area of the animal's body decreases, the thickness of each wool increases, and the inner structure of the wool cylinder becomes lighter.
3. Shirting cover with animal growth gradually loses protective functions from optical radiation, acquiring functions, possibly the main conductor of electromagnetic radiation of the optical spectrum in an animal's organism. With the growth of animal's wool become more transparent for optical radiation, which on them as light transmissions with less losses enters the skin to active structures.
4. In real conditions, when an animal is under the radiation of the Sun or a special source of optical radiation of different spectral composition, the biological effect results in all the energy of radiation that has reached the subcutaneous structures of the body by any of these paths and through the skin and individual wools as light conductors.

IntechOpen

IntechOpen

Author details

Leonid Chervinsky
National University of Life and Environmental Sciences of Ukraine, Kyiv, Ukraine

*Address all correspondence to: lchervinsky@gmail.com

IntechOpen

© 2019 The Author(s). Licensee IntechOpen. This chapter is distributed under the terms of the Creative Commons Attribution License (<http://creativecommons.org/licenses/by/3.0>), which permits unrestricted use, distribution, and reproduction in any medium, provided the original work is properly cited. 

References

- [1] Smith KC, editor. The Science of Photobiology. NY: Pl. Press; 1977. 430 p
- [2] Radha Rani G, Raju GSN. Transmission and reflection characteristics of electromagnetic energy in biological tissues. *International Journal of Electronics and Communication Engineering*. 2013;**6**(1):119-129. ISSN 0974-2166
- [3] Cardona-Hernández Leonel Fierro-Arias MA, Cabrera-Pérez AL, Vidal-Flores AA. Effects of electromagnetic radiation on skin. *Dermatologia Revista Mexicana*. 2017;**61**(4):292-302
- [4] Bashkatov AN, Genina EA, Tuchin VV. Optical properties of skin, subcutaneous, and muscle tissues: A review. *Journal of Innovative Optical Health Sciences*. 2011;**04**:9-38
- [5] Bahar L, Eralp A, Rumevleklioglu Y, Erturk SE, Yuncu M. The effect of electromagnetic radiation on the development of skin ultrastructural and immunohistochemically evaluation with P63. *PSP Fresenius Environmental Bulletin*. 2018;**27**(3):1764-1771
- [6] Chervinsky LS. The action lights on the derma animal's. In: *Extra on International Conf. 1st Congress of the World Association for Laser Therapy «WALT»*; 1996 May 5-9; Jerusalem, Israel. 1996. p. 2922
- [7] Chervinsky LS. Investigation of the light-conductivity of the separate one wool and skins translucence. In: *PITTCO'98*; 1998 March 1-5; New Orleans, Louisiana, USA. p. 652
- [8] Chervinsky LS. About the mechanism of photo reactivation of the biological objects. In: *The European Biomedical Optics Week, BIOS Europe'97*; 1997 September 4-8; San Remo, Italy. 1997. p. 3198
- [9] Chervinsky LS. Primary mechanism of action of optical radiation on living organisms. *International Journal of Biosensors & Bioelectronics*. 2018;**4**(4):204. DOI: 10.15406/ijbsbe.2018.04.00126